

R-SERIES hydraulic BOBICAB II type 1400

Handling of both arms



Traversing unit



Ergonomic control console



Presence sensing mat



MID
Approval

Machine
Certified Compliant

Made in
France

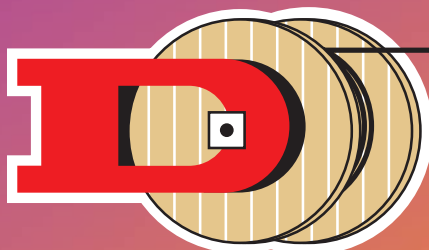

drouaire & fils s.a.
www.drouaire.com

Winder for cable drums Ø 1400 max. and coils

R-SERIES hydraulic BOBICAB II type 1400

Designed for intensive use on logistics platforms.

For the storage of flexible cables Ø 55 max.

Quick change for storage on coiling heads or cable drums.

■ Presentation

- Wide, compact, mechanically-welded chassis fitted with 4 wheels, including 1 steering wheel and 2 pivoting wheels.
- Motorised movement on steerable wheels.
- Protected user platform.
- Fully automatic ground locking mechanism.
- The two arms supporting the cable drum and coiling wheel can be raised, lowered, tightened and untightened using hydraulic jacks.
- Hydraulic system and electrical cabinet integrated on the chassis.
- Drum held between points driven by a rubber plate.
- Fixed coiling head with separate motor, no dismantling required.
- Easy-to-use 4,3" color HMI.
- Protective cradle shielding the user and the machine in case of cable drums falling from the storage rack.

■ Lateral movement using steerable wheels

Allows the machine to be moved laterally and in a line in front of the racks.

Improved deviation radius: possibility of turning 90° easily.

- Using the gear motor with progressive start and assisted steering.
- 1 protected platform allows the operator to move with the machine.
- Unit mounted on wheels, so no need for a guide rail at ground level.
- Safe movement by presence sensing mat for user to move the R Series BOBICAB II.
- Indicators : flash and horn.

■ Coiling head with separate motor

- Coils on easy-to-use coiling head.
- Internal diameter : 350 mm
- Outer diameter : 900 mm (flanges)
- Adjustable width from 50 to 250 mm.
- Max. weight : 80 kg.
- Conical, cut-out pillar for tying.
- Quick cable-blocking mechanism with jam cleat, under a spoke on the coiling head.
- Movable external flange, quick to dismantle.
- Variable rotation speed - 0 to 60 rpm.
- Separate 1.1 kW hollow-shaft motor: no pinions or chains.
- Integrated acceleration ramp.
- Quick stop function on winding mechanism, operated by emergency stop button or triggered by a power cut.
- Unit positioned on the right arm.

■ Cable drum

- Min. outer diameter : 600 mm
- Max. outer diameter : 1400 mm
- Maximum width : 958 mm
- Maximum weight : 1000 kg
- Separate hollow-shaft motor : no pinions or chains.
- 2.2 kW motor with electronic frequency variator for speeds from 0 to 85 rpm.
- Driven by adherence of 8 rubber buffers.
- Integrated acceleration ramp.
- Quick stop function on winding mechanism, operated by emergency stop button or triggered by a power cut.

■ Hydraulic cable-drum lifting system

- Cable drums positioned between points with a lifting system using hydraulic jacks, controlled by button pad.
- Anti-return piloted electro-compressor valves for safety in case of pipe or cable rupture.

■ Hydraulic cable-drum tightening

- Tightening and untightening of arms by hydraulic jacks for holding cable drums simply by pushing a button.
- Anti-return piloted electro-compressor valves for safety in case of pipe or cable rupture.
- Controlled by button pad.

■ Traversing unit

- The movable trolley allows cable traversing using cable channels on entry and exit.
- With an electronic, double-preselection measuring counter by the HMI, allowing high-speed winding then slowing before stopping automatically at the pre-selected length.
- Cuts counter integrated in the HMI, reset by entering a code.
- Calibrated measuring wheel: 2 turns = 1 metre.
- Two-direction, hollow-shaft precision encoder for reliable, precise counting. Mounted on the measuring wheel support.
- "Cable presence" detector which stops the machine when the cable ends.
- Cable cutter with double-effect hydraulic shear, 60 mm capacity (85 mm opening).

■ Electronic traversing

- Allows the cable to be stored on the drum or coiling head by setting the speed of the trolley in relation to the external diameter of the cable.
- Proportional to winding.
- Inversion parameters can be set on the touch screen, with self-learning.
- Can be released for manual use.
- Motor driven by frequency converter.

■ Electrical equipment

Fully integrated in the chassis - shock-proof. Accessed by dismantling two screws.

- Schneider PLC.
- 3 Schneider variable speed controllers (winding on cable drum or coiling head, traversing, travel).
- Wattage : 5 kW.
- Voltage : 230 V mono 50 Hz + earth.

■ Control panel with touch screen, allowing the following operations :

- Setting of parameters on the touch screen by the operator.
- Visualisation of the power supply.
- Machine start-up.
- End of line.
- Unwinding speed settings.
- Settings for traversing rates, with possible manual correction during operation.
- Reference on left-hand point.
- Programming of length to be wound.
- Electronic length metering.
- Visualisation of length parameters during winding: cable diameter, total length, position of the traversing trolley.
- Movement of the winder with choice of direction (left - right, front - back).
- Visualisation of errors.
- 1 emergency stop button located above the touch screen.
- 2 buttons for controlling the hydraulic shear, so that both hands are used at the same time.

■ Accessories

- Round mirror to allow users to see the cable properly during winding on the right arm.
- Hold-all tub.
- String dispenser with integrated cutter.
- Plastic film dispenser on the traversing trolley.
- Electrical insulating stick.
- Fan

■ Paint

- Blue RAL 5010.

Option : Return pulley

- Allows unwinding of cable drums situated on either side of the BOBICAB II, thus preventing the operator from turning the machine 180° (see principle in Racks notice).
- Transmission system fixed on the traversing trolley.
- Improved curvature radius in order to pass larger cables.

Option : Extendable coiling head

For winding coils with varying internal diameters.

- Quick and easy adjustment of the 4 sections of the coiling head simultaneously.
- Adjustable pillar diameter : 300 to 800 mm
- Max. external diameter : 900 mm
- Adjustable width : 50 to 250 mm

Option : Remote maintenance

Allows remote breakdown diagnosis and modification of automaton programming.

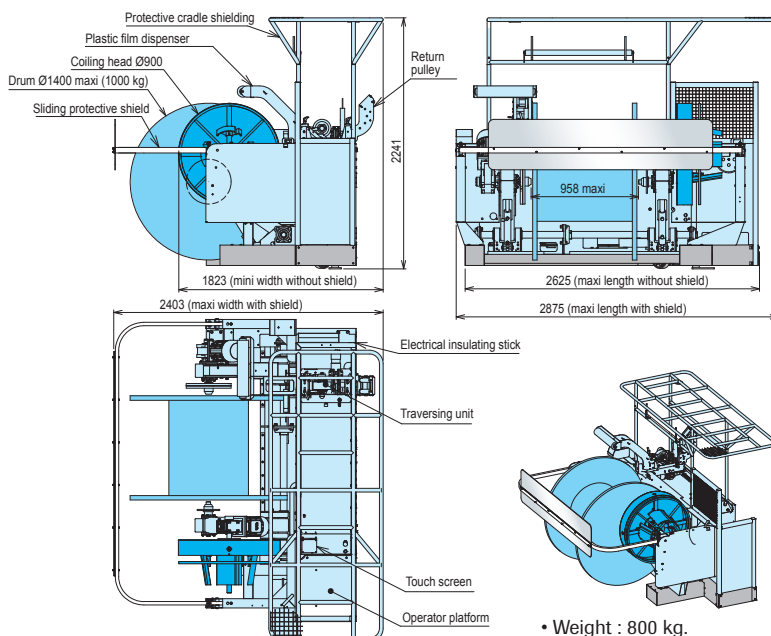

DROUAIRE & FILS S.A.

47160 Villefranche-du-Queyran - FRANCE

Tel. : +33 553 88 70 87 - Fax : +33 553 88 76 49

contact@drouaire.com - www.drouaire.com